

110 kV DRY TYPE CABLE TERMINATOR

Condenser Graded, Paperless RIF® Technology

Highest Voltage	126 kV
Conductor Cross-Section	≤1200 mm ² or 2500 kcmil (up to 2500 mm ² on demand)
Creepage distance	4000 mm
Weight	45 kg
Applicable Standard	IEC 60840
Operating Environment	- 50°C to 50°C Altitude ≤3000 m Outdoor or indoor

The RIF® Cable Terminator uses an assembly gap that is located in the equipotential compartment, which eliminates the need for an insulation filler. This air gap makes for a simple more reliable design that requires no special sealing and is free of leakage problems.

It uses our proprietary dry type capacitance-graded insulation body to control the electric potential gradient at the contact area keeping the electric potential gradient of the inner and outer insulation very uniform. A robust insulation design proven on our RIF® bushings up to 362kV ensures a cable terminator with a longer life expectancy.

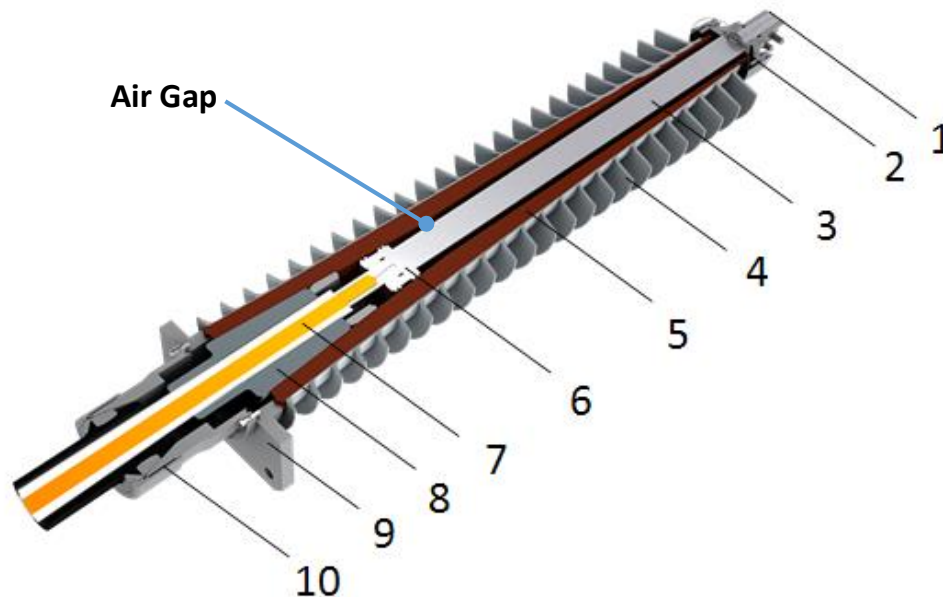

1. Terminal
2. Corona Shield
3. Conductor
4. Silicone Rubber Sheds
5. RIF® insulation
6. Tulip contact
7. Cable
8. Stress cone
9. Mounting flange
10. Sealing end-tube

Key benefits for our customers:

- A condenser graded design for more uniform control of the electric potential gradient.
- Leakage free design.
- Simple on site installation with the terminator only requiring 300 mm of polished cable insulation surface.
- High mechanical strength for a very robust installation and longer life expectancy.

Cable/Air Terminator

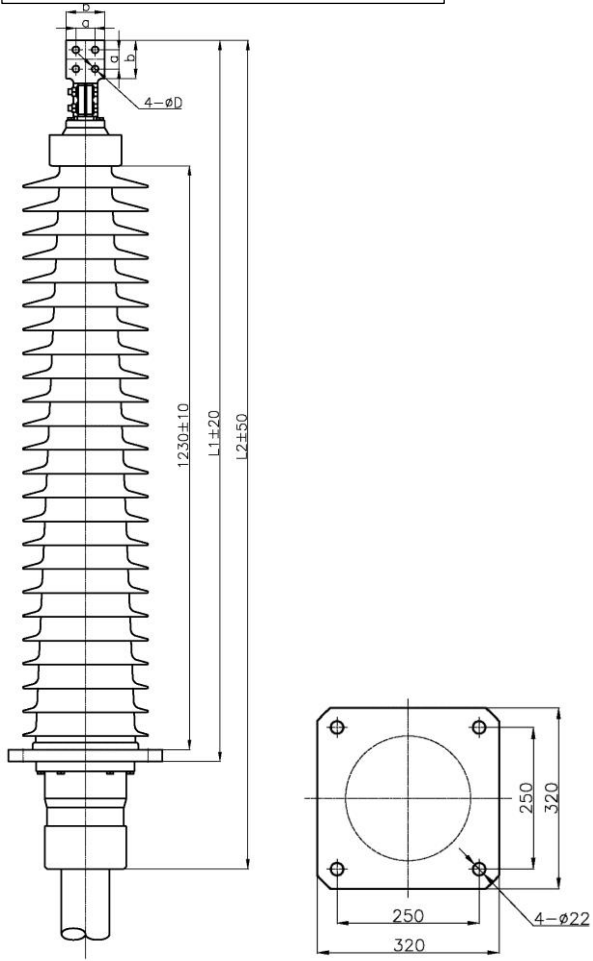

GIS/Cable Terminator

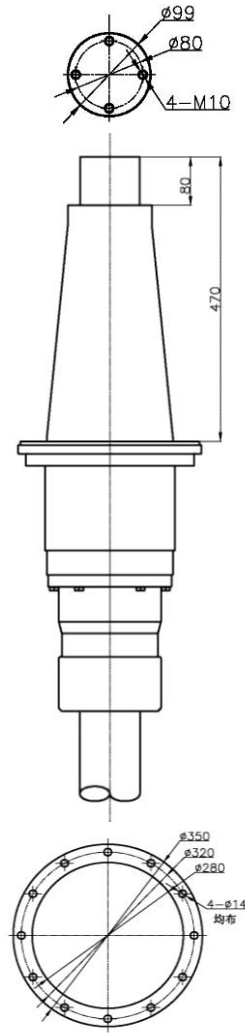

Cable Joint Terminator

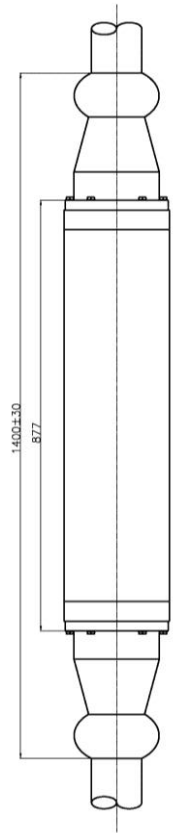

Cable Size		L1	L2
kcmil	mm ²	mm	mm
≤1250	≤ 630	1520 ± 20	1750 ± 50
1700 - 2000	800 - 1000	1540 ± 20	1780 ± 50
2500	1200	1580 ± 20	1800 ± 50

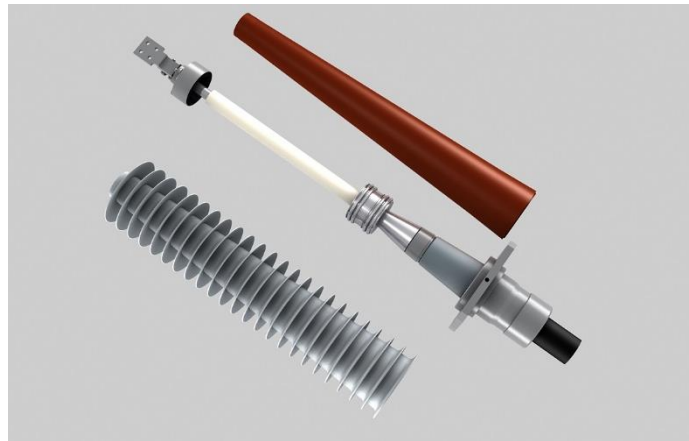

Designs available for 25 kV, 35 kV and 69 kV applications. Contact RHM International for details.

CONTACT US

Contact Us

RHM International
280 Clark Road
Brookline, MA 02445
USA

Tel: +1 888 495 0008

Fax: +1 617 608 0274

www.rhmintl.com

RHM International considers all inquiries, worldwide.

For any inquiries about the products and their availability, please call or email us at: info@rhmintl.com