

The resin-impregnated fiberglass technology with its large safety margins and simpler manufacturing processes enables producing a bushing that is ultra-reliable, explosion-resistant and maintenance-free

## ABSTRACT

Paper-insulated bushings (OIP and RIP) have been the dominant bushing type for the power transformer industry for many years. However, as our transformer assets age, bushing failures can become more frequent. Resin-impregnated fibre bushings offer the user a paperless and dry-type alternative for MV, HV and EHV condenser transformer bushings. Two technologies are currently offered: resin-impregnated fiberglass (a proprietary technology trademarked RIF®) and resin-impregnated synthetic (RIS). This article will discuss the RIF® bushing technology, which offers an extended range of capabilities including an optional line of smart bushings that use integrated monitoring components.

## KEYWORDS

resin-impregnated fibre bushing, RIF® transformer bushing, smart RIF®, partial discharge

# RIF® bushings

## The paperless, dry-type bushing technology

### 1. Introduction

The main purpose of a transformer bushing is to safely transfer power through the earthed transformer tank. OIP and RIP type bushings have for many years been the industry standard for transformers, and in general have performed satisfactorily. However, as our transformer assets age, paper deterioration in these bushings can eventually cause these bushings to fail, some even catastrophically.

The purpose of this article is to introduce a new dry-type paperless bushing technology that is currently on the market – the resin-impregnated fibre bushing. Currently, there are two technologies on the market: resin-impregnated fiberglass (a proprietary technology trademarked RIF®) and resin-impregnated synthetic (RIS). The RIF® technology has been on

the market since the early 2000s while the RIS technology is a relative newcomer to the market. These technologies now provide the user with better levels of safety and reliability for their expensive transformer assets, thereby contributing to reduced lifecycle costs.

This article discusses the design, construction, validation and self-monitoring features of the RIF® dry-type bushing, which is the older and more established resin-impregnated fibre bushing technology.

### 2. Design and construction of the RIF® bushing

RIF® transformer bushings have been manufactured for voltage levels ranging from 15 kV to 500 kV and for currents up to 6000 A since 2006, with over 19,000 units currently in-service worldwide.

These bushings have proven to be ultra-reliable under all types of operating and environmental conditions. To date the only reported failure occurred when a customer left the test tap ungrounded. Field related issues have been minor, restricted primarily to silicone rubber damage from rough handling or shipping issues.

The RIF® bushing utilizes a finely graded condenser design and a core insulation that is composed of fiberglass impregnated with epoxy resin wrapped between capacitive screens. The outer insulation for the RIF® bushing are silicone rubber sheds that are adhered directly to the condenser core. This ensures there is no gap or opening in the overall bushing structure and eliminates the need for filler fluid or material. As mentioned previously, the electrical field is controlled by a finely graded capacitive core which ensures a linear surface potential profile from the conductor to the grounded flange (100 % to 0 %), which greatly improves its flashover resistance. In addition, the thermal insulation strength of the resin-impregnated fiberglass is IEC Class B (temperature limit rating of 130 °C) which gives the RIF® bushing a larger thermal margin than other bushing types. Finally, the simpler manufacturing process, which is primarily a wrapping and heat curing process, introduces minimum internal stresses in the capacitive core that can affect the long term operational life of the bushing [1].

The RIF® technology also has the design flexibility to provide “like for like” replacements for vintage oil-filled bushings with non-standard dimensions, including the narrower style of some older bushings.

RIF® bushings have a proven record of operational reliability at very low and high temperatures. All the required industry standard temperature cycling tests have been performed and passed, but to really stress this bushing technology a combined mechanical and thermal endurance stress test was carried out on a 110 kV RIF® bushing, Fig.1.

Figures 2 to 7 show the various set-ups that were used for the combined endurance test.

Prior to the start of the combined endurance test, power frequency voltage withstand, dielectric dissipation factor, partial discharge and capacitance were

measured and recorded (see Table 1, Row 1). The test bushing was then placed in the environmental chamber and the temperature raised and held for 17 hours at 140 °C. After the 17 hours at 140 °C, the temperature was returned to ambient temperature and the test bushing submerged in water for four hours, Fig. 2. Upon removal from the water bath, partial discharge and dissipation factor were measured with the partial discharge values showing less than or equal to the pre-test values, and the dissipation factor remaining unchanged (see Table 1, Row 2).

Next, a low temperature cycle test was done, where the test bushing was subjected to -50 °C for 17 hours. After 17 hours at -50 °C, the temperature was raised to ambient temperature and a power frequency withstand test was done, with the partial discharge and dissipation factor measured (see Table 1, Row 3). The partial discharge values remained less than or equal to the pre-test values, while the dissipation factor increased marginally from 0.31 % to 0.33 %.

A second 17-hour low temperature (-50 °C) cycle test was done, where 788 A was injected through the test bushing during the last two hours, Fig. 3, 4 and 7. After the current injection, the temperature

was raised to ambient temperature and a power frequency withstand test was done, with the partial discharge and dissipation factor measured (see Table 1, Row 4). The partial discharge values still remained less than or equal to the pre-test values, while the dissipation factor had reduced to 0.32 % but still remained marginally higher than the pre-test value of 0.31 %.

The next part of the endurance test cycle raised the temperature to 105 °C. After 15 hours at 105 °C, a one-minute 1450 N cantilever load test was done, followed by a power frequency withstand test and measurement of the partial discharge and dissipation factor (see Table 1, Row 5). The partial discharge values still remained less than or equal to the pre-test values, while the dissipation factor remained at 0.32 %, marginally higher than the pre-test value of 0.31 %.

The temperature was returned to ambient and then raised again to 105 °C for a second high temperature test. After 16 hours at 105 °C, a one-minute 3450 N cantilever load test was done. After the one-minute 3450 N cantilever test, a fixed load of 3300 N was maintained for the duration of the endurance test cycle, Fig. 5, which involved a third low temperature (-50 °C) cycle test for 16 hours before raising

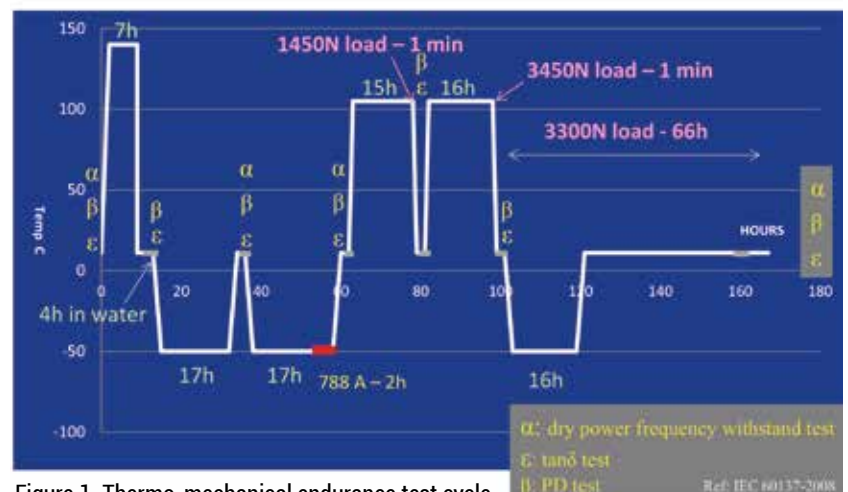

Figure 1. Thermo-mechanical endurance test cycle





Figure 2. Thermal shock test



Figure 3. Low temperature test with current injection



Figure 4. Low temperature test with current injection



Figure 5. Cantilever load test at low temperature



Figure 6. Heavy cantilever load test at 105 °C



Figure 7. Low temperature test with current injected

Table 1. Test results from thermo-mechanical test

Steps	Dry Power Frequency Voltage Withstand Test	PD (pC) @			tan δ (%)	Capacitance (pF)
		126 kV	110 kV	77 kV		
Preparation before test	230 kV/1 min	3-4	3-4	2-3	0.31	434.7
	(Passed)					
After hot temperature and water submersion cycle	Not tested	3-4	2	Background noise	0.31	438.9
After first low temperature cycle test (-50 °C)	230 kV/1 min	3-4	2-3	Background noise	0.33	434.5
	(Passed)					
After second low temperature cycle test (-50 °C and 788 A)	230 kV/1 min	3-4	1-2	Background noise	0.32	433.3
	(Passed)					
After cantilever load test (105 °C)	230 kV/1 min	3-4	2-3	Background noise	0.32	437.1
	(Passed)					
After 66 hours cantilever load test (16 hrs. @ -50 °C and 50 hrs. @ ambient)	230 kV/1 min	3-4	2-3	Background noise	0.32	431.9
	(Passed)					

the temperature to ambient and maintaining the 3300 N load for another 50 hours. Upon completion of the combined endurance test, a final power frequency withstand test was done, and the final partial discharge and dissipation factor values recorded (see Table 1, Row 6). The partial discharge values still remained less than or equal to the pre-test values, while the dissipation factor remained at 0.32 %, marginally higher than the pre-test value of 0.31 %.

The test results in Table 1 confirm the large margins built in the RIF<sup>®</sup> bushing and show that the stability and integrity of the bushing remained unaffected, even when subjected to stresses greater than what is seen in traditional type tests.

As can be clearly seen from Table 1, the test results for the partial discharge values

**The thermal insulation strength of the resin-impregnated fiberglass is class 130 °C, which gives the RIF<sup>®</sup> bushing a larger thermal margin than other bushing types**

after the combined thermal-mechanical endurance test remained less than or equal to the pre-test values, while the dissipation factor remained marginally higher (3.2 %) than the pre-test value, thereby showing a consistent performance under extremely harsh operating conditions.

### 3. The self-monitoring smart RIF<sup>®</sup> bushing

The main insulation of a condenser graded bushing can be thought of as a series of capacitors separating the conductor

and ground. In such a configuration, the process of insulation breakdown initiated by a defect is sequential; the insulation of one of the capacitive screens is damaged leading to the failure of other screens and eventually the breakdown of the entire insulation. As screens fail, the reduction of series connected capacitors causes a gradual increase in capacitance and capacitive current. This variation in capacitance and capacitive current can be measured to provide an indication of the degree of damage. This is the principle that is used in the smart RIF<sup>®</sup> bushing.

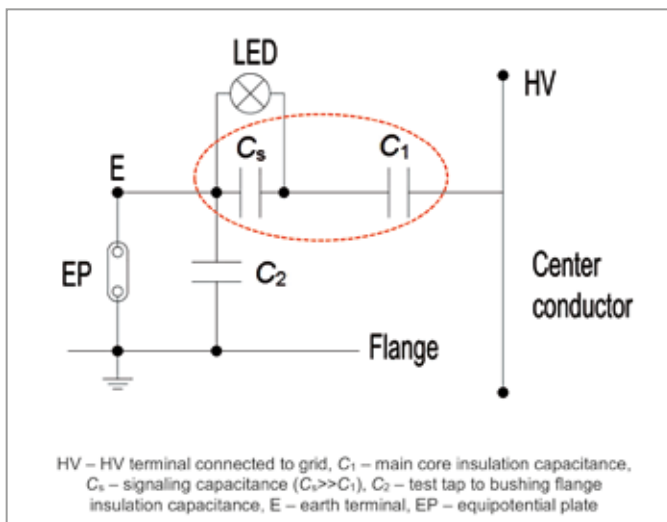

Figure 8. Smart RIF<sup>®</sup> bushing schematic representation

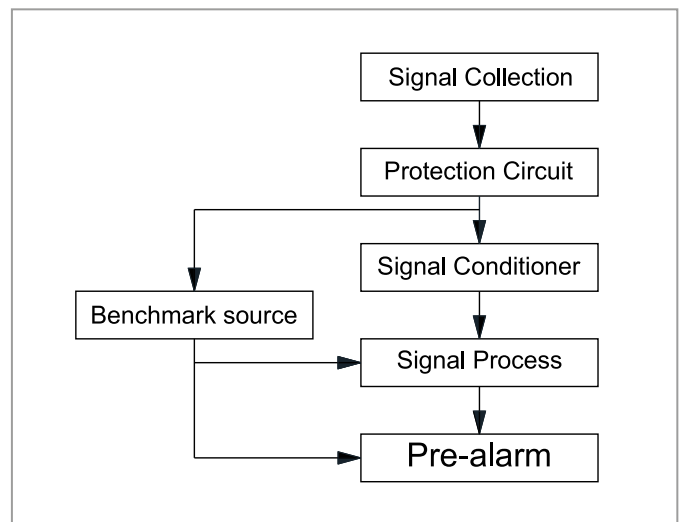

Figure 9. Pre-alarm sensor circuit diagram

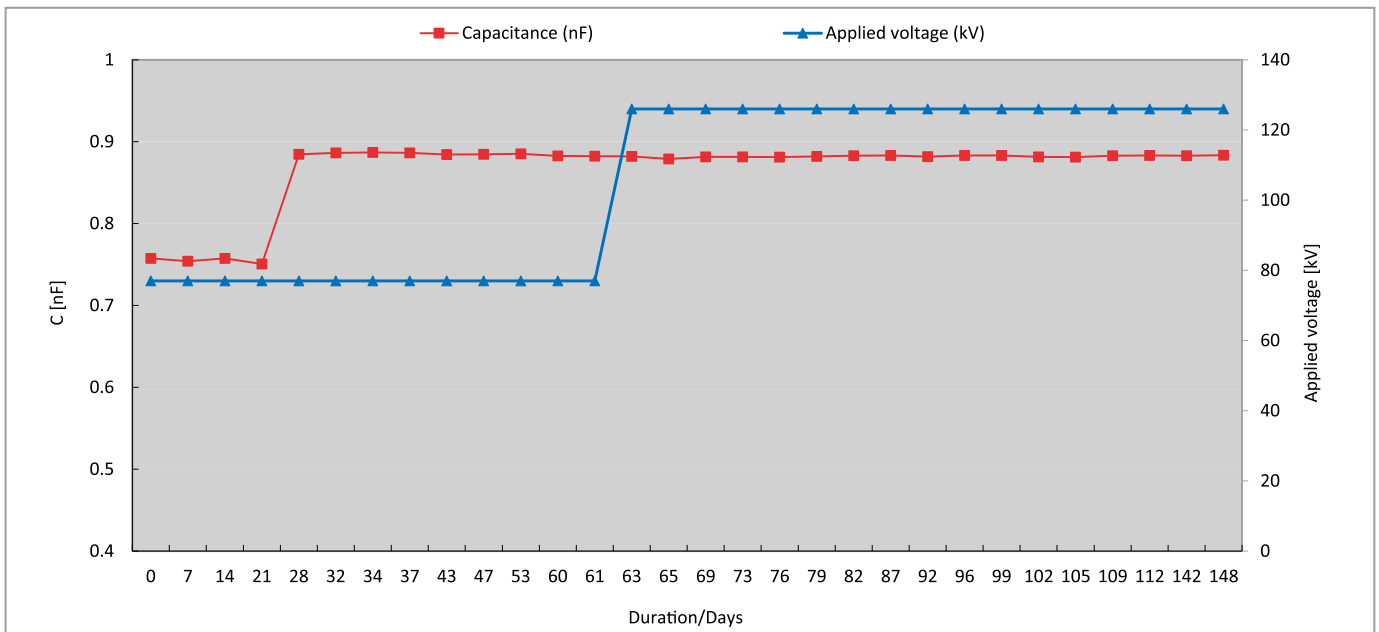

Figure 10. Test data for 126 kV RIF® bushing with artificially damaged insulation

The smart RIF® bushing is manufactured with a large signalling capacitance  $C_s$  that is connected in series with the last capacitive screen of the high voltage  $C_1$  capacitance ( $C_s \gg C_1$ ) to form an integrated system where  $C_s$  and  $C_1$  are sealed together within the primary core, Fig. 8. The resulting capacitive divider provides an accurate way of measuring capacitance (and capacitive current) of the condenser core insulation. This is accomplished by bringing the two ends of

$C_s$  out to a smart measurement terminal where a sensor is installed to collect and process the signal, Fig. 9. The processed signal is then compared to a benchmark voltage that is set at the factory, so no field calibration is required. The sensor is calibrated to provide a pre-alarm of a deteriorating insulation condition and is provided with two signalling options: an LED lamp for local visual indication or a signalling cable when remote monitoring is required [2].

It should be noted that the receipt of a pre-alarm signal is a very preliminary indication of the onset of a fault within the capacitive layers. The safety margins that are designed into the bushing provide a long latency period from a pre-alarm signal to when the bushing becomes unfit for operation. To validate this, lab tests were conducted on bushings that had up to 25 % of their condenser core insulation damaged using an elevated lightning impulse withstand voltage. Figure 10

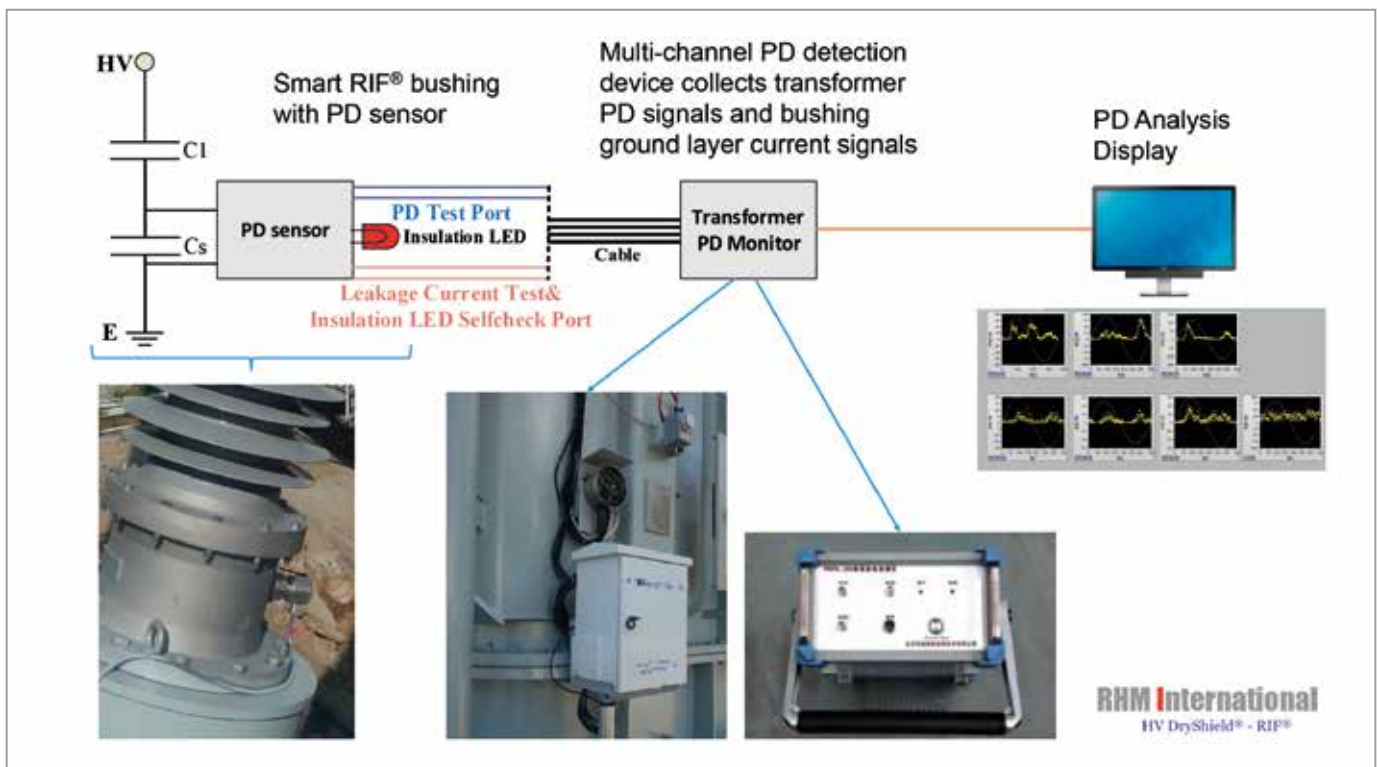

Figure 11. PD detection system architecture



shows the data from one such test on a 126 kV bushing.

The bushing which initially had 13 % of its condenser core insulation thickness damaged was energized at 77 kV for one month. After Month 1, the insulation damage was increased to 25 % which can be seen by a sharp change in capacitance, Fig. 10, and left energized at 77 kV for another month. After Month 2, the energized voltage was increased to 126 kV and the damaged bushing left energized for another three months. The test was stopped after five months with no sign of an imminent failure.

These lab tests showed that an insulation fault in a RIF® bushing propagates slowly and that even if an initial insulation fault triggers a pre-alarm, there is enough time for inspection, maintenance or replacement (at least three months).

#### 4. Using the smart RIF® bushing to detect partial discharge activity within the power transformer

Finally, an inexpensive system has been developed for capturing and processing high frequency transient current pulse signals (100 kHz – 500 kHz) running through the smart RIF® bushing, which are generated from partial discharge activity inside the power transformer. The system requires the smart RIF® bushing to be equipped with a special PD sensor (that plugs into the bushing's smart measurement terminal). Depending on the number of smart RIF® bushings installed on the transformer, more accurate the locating of the PD activity will be. The PD sensors are hardwired to either an online or portable PD detection device for collecting and processing the PD signals from the transformer [3]. Figure 11 shows a typical connection configuration for the smart RIF® transformer partial discharge detection system.

For field use, a portable PD detecting device can be used [4]. The device does not need an external power source as it is battery powered and site operation is very straightforward. The portable device is connected to a laptop via WIFI or Ethernet cable to upload data. Finally, all monitoring data complies with the IEC 61850 communication standard for

## The test results showed a consistent performance of RIF® bushings under extremely harsh operating conditions

easy integration into present and future digital substations.

### Conclusion

The objective of this article was to make the reader aware of the reliability and safety benefits of the resin-impregnated fibre bushing. Even in case of failure, the impact to the transformer would be dramatically reduced, if not avoided altogether.

Since the early 2000s, the RIF® bushing has pioneered what is now the state-of-the-art in dry-type bushings with the specific feature of being a paperless insulated technology, impervious to tough climates. Over 19,000 units are safely in service worldwide; they have demonstrated great reliability, but perhaps more importantly have become a way to consistently shield transformers from the impact of catastrophic bushing failures. In addition to being a truly maintenance-free technology by design, this is a bushing technology option that today's users and OEMs can turn to to provide a value of safety not previously available for their personnel and equipment.

### References

- [1] T. Tu, E. Euvrard, R. Wang, *Development and Application of Resin Impregnated Fiberglass Transformer Bushing*, INMR World Congress, Seoul, Korea, April 2011
- [2] R. Middleton, E. Euvrard, J. Zhuo, *A Novel Built-In Insulation Condition Monitoring System Enabled by Dry Type by Dry Type Technologies*, CIGRE Canada Conference, Vancouver, BC, Canada, October 2016
- [3] T. Tu, E. Euvrard, Z. Liu, *Combining Dry Type Resin Impregnated Fiberglass Paperless Transformer Bushings with Built-In Novel Insulation Monitoring Function*, IEEE PES Conference, Chicago, USA, 2014
- [4] T. Zhuo, X. Zho, H. Wang, R. Wang, R. Middleton, E. Euvrard, *The Development and Operation of Novel Built-In Insulation Monitoring Functions in the Management of HV Bushings*, INMR World Congress, Munich, Germany, October 2015

### Authors



**Eric Euvrard** has an extensive international engineering background having held different technical and managerial functions in Europe, USA and China in commodities, automotive, aerospace, advanced nanomaterials and fiber optics networks industries, before creating RHM International in 2005 where he presently serves as President. Eric obtained his BSc in chemical engineering from Toulouse National Engineering School – ENSCT in France, an MSc in engineering from Georgia Tech in Atlanta, USA, and EMBA from IMD in Lausanne.



**Robert L. Middleton** was born in 1948 in Winnipeg, Canada. He received his degree in electrical engineering from the University of Manitoba in 1971. He is a registered professional engineer in the Province of British Columbia. He has an extensive background in generation and transmission engineering including quality assurance. He has served on several CSA, CIGRE and IEC working groups and co-authored numerous technical papers. He is presently the Chief of Technology and Engineering for RHM International, a manufacturer of high voltage dry type current transformers and bushings. Prior to joining RHM International he worked over 40 years at two western Canadian provincial electrical utilities.